

# STENTERS



## Stenter - mod. RAM/F 3,80m modular bays

Stenter mod. RAM/F main features:



- **Heating system**, equipped with one re-circulation fan, one oil battery, blowing channels, air recovery channel and filter. To ensure uniform heating and air distribution, bays are opposed on left and right side.

In order to reduce electrical consumption as the oven reaches working temperature, all re-circulation fans are controlled by an inverter wich changes rotation speed as temperature increases
- **Oven structure** with silicone rubber sealing doors placed all along the sides, in order to grant easy inner access. Side doors as well as upper coverings are made of sheet-zinc panels containing high-density rock-wool. **The oven is built in order to guarantee maximum sealing and insulation**
- **Air exhaust system**, consisting of upper exhausters connected to two air channels placed outside the oven along the upper sides. In order to allow local and precise air suction adjustments, variable size openings are provided for every field
- **Stenter**, consisting of a vertical chain system with pins, equipped with automatic lubrication. Diverging field is controlled by two independent A.C. motorizations equipped with inverter and activated by two sensors.

Fabric is coupled by two pairs of pneumatically driven rotating brushes. A pneumatic system also controls correct tension of the stenter chain automatically.

Stenter guides are divided in sections, one for each field. Each section is mounted on a motorized transversal threaded shaft, thus allowing to differentiate stenter width change. **Width of each field is controlled through PLC equipped encoders and displayed through on-screen diagram.**

The stenter has an Inverter equipped A.C. motorization with local potentiometer for line synchronization

>>

# STENTERS



- **Thermo-Regulations mod. TR**, with temperature control system, one for each battery, consisting of:
  - three-way pneumatic command modular valve, equipped with electro-pneumatic transducer
  - PT 100 temperature detector
  - PID electronic control with digital display
- **Electrical board & PLC**. Motorization components are gathered on modular control panels. Main functions are displayed on screen. Synchronization with the rest of the line is obtained through inverter controlled A.C. motors with vector function. General synchronization is obtained through an input signal to the cards controlling the inverters. General speed adjustment is obtained through moto-potentiometer and signal amplifier. Electronic cards for inverter adjustment are equipped with potentiometric correction in percentage.

AIGLE stenters can also be built with steam or gas heating.

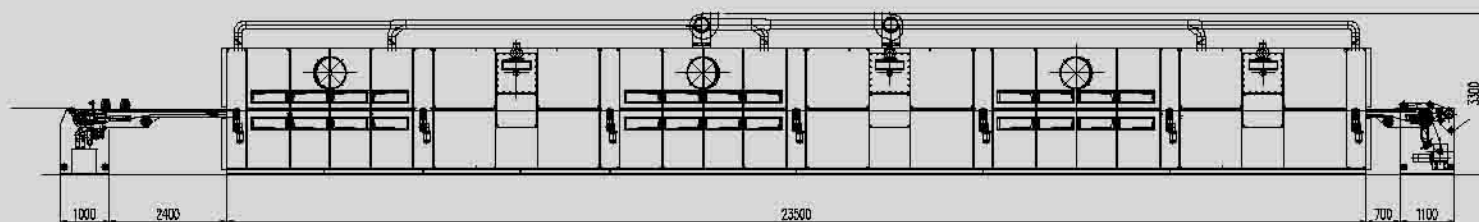
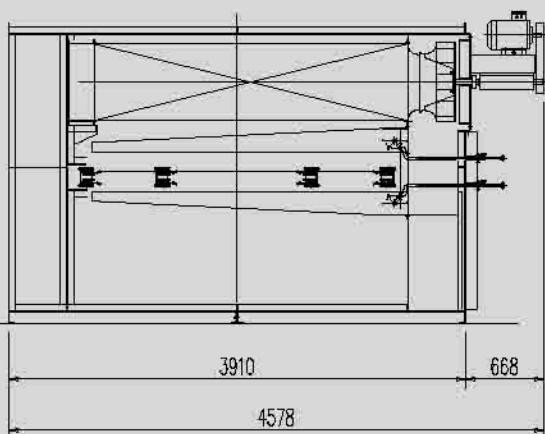

## TECHNICAL DATA

Single bay heating power	120.000 KCal/h
Single recirculation fan electrical power	5,5 Kw
Max. working temperature	to be agreed upon (220° C max.)
Useful width	to be agreed upon
Max. mechanical speed	40 m/min. max.
Power supply	400 V/50 Hz/three-phase
Compressed air	7±1 Kg/cm <sup>2</sup>



ISO 9001:2000  
Certified Quality System  
IT-50269

# AIGLE