

# FLOCKING FABRICS AND ROLL MATERIALS

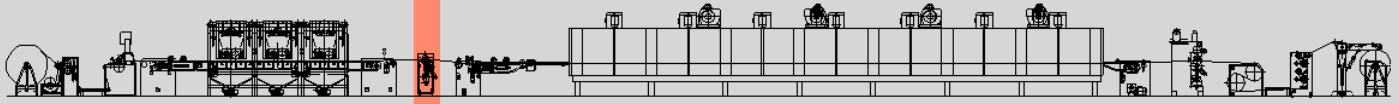

## Blowing/Embossing Machine - mod. AP1

The **Blowing/Embossing Machine mod. AP1** is used to emboss flocked fabric. It must be placed between the flocking unit and the oven in order that it operates while the adhesive is still wet. The embossing effect is obtained by blowing air through rotary screen holes.



The machine consists of:

- Rotary screen head, synchronized with general motorization
- Screen tensioning device
- Screen position micrometric adjustment system
- Pneumatic lifting of the whole group
- Blowing blade placed into the rotary screen, equipped with all necessary devices to allow adjustment of:

- air quantity
- distance between blade and rotary screen
- inclination

- Rotary screen group supporting frame, with rectified counter plate
- Blowing fan
- Control panel

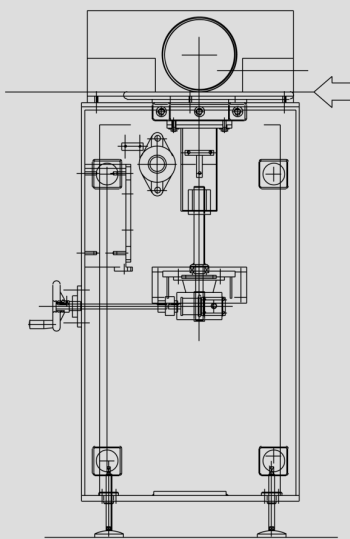

### TECHNICAL DATA

Useful width	to be defined
Mechanical speed	max. 40 m/min.
Power supply	400 V/50 Hz/three-phase
Installed power	17 kW
Compressed air	7±1 Kg/cm <sup>2</sup>

Member of CISQ Federation



CERTIFIED MANAGEMENT SYSTEM  
ISO 9001 - ISO 14001



# AIGLE